

Accu-Switch Instruction Booklet

The "Direct Drive Difference" in Switch Gauges

INTRODUCTION

The Accu-Switch series of pressure Switch Gauges from 3D Instruments offers a new standard for a mechanical pressure gauge with high/low switch contacts. The long life, gold plated switch contacts can be wired directly to electrical circuits to provide for operational alarms or can be used to "stop/start" a variety of electrical equipment...pumps, valves, motors, etc. The Accu-Switch gauge pointer acts as both a pressure indicator and a switch pole which completes a circuit when it comes in contact with one of the field-adjustable limit contacts.

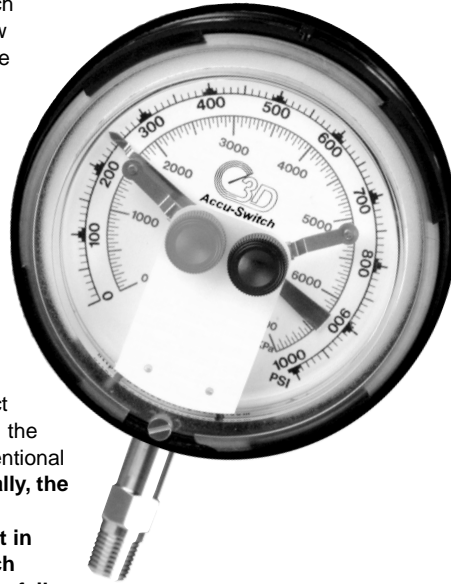

Utilizing our unique helical bourdon "direct drive" pressure measurement technology, the antiquated C-bourdon tube in most conventional pressure gauges is eliminated. **Additionally, the gearing, linkages, levers and springs required to generate pointer movement in the conventional pressure gauge, which are highly prone to wear and premature failure in high vibration and pulsation applications, are also eliminated!!**

The Accu-Switch Switch Gauge is designed to provide superior performance in the harshest of process environments! It is housed in a robust weather-resistant 4 1/2" ABS case and features corrosion resistant materials throughout – ABS case, Inconel X-750 helical bourdon tube and stainless steel process connection.

The Accu-Switch Switch Gauge incorporates some very revolutionary design concepts... from our unique "Dyna-Mount" flange/fitting system, whereby the process connection fitting can be adjusted from bottom to back configuration in the field with only the use of a screwdriver to the external zero adjustment to minimize potential maintenance.

The combination of sophisticated pressure measurement technology, robust design and long life switch contacts makes the Accu-Switch from 3D Instruments the ideal choice for your demanding pressure monitoring, alarm or switching applications.

PRODUCT OVERVIEW

CAUTION:

The Accu-Switch series Switch Gauges are suitable for use in Class I, Division 1 and 2, Groups C and D hazardous locations when operated with suitable precautions.

WARNING: DEVIATION FROM THESE INSTALLATION INSTRUCTIONS MAY LEAD TO IMPROPER DEVICE OPERATION WHICH COULD CAUSE PERSONAL INJURY TO OPERATORS OR OTHER NEARBY PERSONNEL.

DESCRIPTION

The 3D Instruments Accu-Switch series pressure switch-gauge is a mechanical pressure gauge in a 4 1/2" (114 mm) case with high/low switch contacts. Utilizing a "direct drive" movement, the conventional C-bourdon tube used in most other pressure gauges is eliminated as are the gears, links, levers and springs used to connect the C-tube to the indicating pointer. In contrast, the Accu-Switch series uses a special helically-wound coil of Inconel metal, directly connected to the indicating pointer. Fewer parts means fewer problems. Regular recalibration is eliminated because there are no complex, wear-prone parts. Linearity is built-in; no span adjustment is needed. The zero adjustment is accessible from the front of the gauge. The "direct drive" design provides for longer life than even liquid-filled conventional gauges in severe service applications. Accuracy is +/-1% of span across the scale.

The pressure connection fitting is user adjustable on most models to either a bottom or a back connection - refer to page 9 for details. The gauge can be outfitted with an optional mounting flange that can be field adjustable to either a front or back configuration.

The two adjustable high/low limit contacts can be used to activate alarms or shut-downs. The high/low adjustment knobs are color-coded (Red for Low, Black for High) and match the switch connection wires.

The basic design is inherently safe due to the very small tube I.D. The small diameter of the spiral tube effectively limits the flow rate of pressure media into the case. Polycarbonate plastic is used for the front lens and a rubber blow out plug is used in the rear wall of the case.

Corrosion resistant materials are used throughout making them applicable for most process applications. The case is ABS plastic, with a polycarbonate lens. The helical bourdon tube is Inconel. The pressure connection stem is 316 stainless steel, and all hardware is stainless steel.

The "quality oriented" design of the Accu-Switch Switch Gauge makes it the ideal choice when considering various measurement, equipment switching and/or alarming options for vibration and pulsation laden process applications. **The "direct drive difference" helical bourdon tube system, featuring only 1 moving part and a 6 year product warranty, ensures a much longer service life than the conventional Switch Gauges.** Additionally, our case size and various flange options allow for easy mounting and installation into existing panel cutouts.

OPERATING INSTRUCTIONS

MOUNTING

The Accu-Switch Switch Gauge has been calibrated at the factory in a vertical position and such should be installed and used in an upright orientation. It can be mounted on a piece of pipe, installed in a control panel or on a flat vertical surface taking care not to damage or distort the gauge case. Distortion of the case may cause the internal assemblies to bind and not function properly.

NOTE: Factory calibration is performed with the gauge dial mounted in a vertical position. If the gauge is to be used in some other position, the factory calibration should be verified in this position.

CAUTION: A rubber blowout plug is located in the back of the case. Do not mount the gauge with the blowout plug flush against a surface.

On most models, the pressure connection fitting can be located for either bottom or back attachment and can be changed in the field.

NOTE: Refer to page 9, Figure 3 for instructions on how to change the position of the pressure connection fitting.

NOTE: Do NOT attempt to change the connection fitting position on gauge models with pressure ranges below 60 psi.

To avoid contaminating the pressure measuring system in the gauge, leave the protective cap on the connection fitting until just before the connection is made. The fittings on the gauge and on the pressure line must match. A thread sealant such as Teflon tape is suggested when making the connection. Take care not to clog pressure opening. Make sure the sealant used is compatible with the pressure media. Use proper wrenches to tighten or loosen connection. DO NOT use the gauge case as a

handle for screwing the gauge into place on the pressure fitting. DO NOT over tighten the fittings since they may be damaged beyond repair. DO NOT exceed rated gauge pressure.

All 3D Instruments Accu-Switch series gauges incorporate a unique needle dampening system that slows down needle bounce. However if large scale and/or high-frequency pressure fluctuations are expected in the pressure system, it may be desirable to attenuate these by use of a pulsation dampener. Contact factory for assistance.

As standard, all 3D Instruments Accu-Switch series gauges are equipped with a 316 SS particulate filter installed in the fitting connection of the gauge to prevent most particulate matter from plugging the spiral tube.

WIRING

A pressure condition at or under the low setpoint causes a switch closure on the red wire (low) and white wire (common). A pressure condition at or above the high setpoint causes a switch closure on the black wire (high) and white wire (common).

NOTE: The white wire is common with the pressure fitting (ground). Refer to page 7, Figure 1 for a circuit diagram.

Each switch is normally open rated at 0.25 amps @ 125 volts (AC or DC). The switch contacts are gold plated at points of contact. Use stranded copper wire, 18 to 22 AWG for switch connections. Use spade or ring terminals when connecting to terminal blocks. Use wire nuts or butt connectors for pigtail connections. Conduit is recommended to protect wires from being damaged.

OPERATING INSTRUCTIONS

HAZARDOUS AREA OPERATION

The Accu-Switch contains two dry contacts and can be operated with suitable precautions in Class I, Groups C & D locations. Refer to NFPA Standards - numbers 70 and 493 for details.

OPERATION

When pressure is applied to the Accu-Switch gauge, the needle will travel clockwise for increasing pressure and counter-clockwise for decreasing pressure. The limit switches will be activated when the pointer comes in contact with the low or high setpoint contact arm. The force of the pointer causes the contact arm to flex or "tilt" causing a wiping action. This wiping action cleans the contacts and assures high reliability. In addition, all contact points are gold plated.

To verify proper operation of the Switch Gauge, the setpoint(s) of interest should be tested prior to finalizing the positioning and installation of the Switch Gauge. The recommended low setpoint range is from zero to mid-scale. The recommended high setpoint range is from mid-scale (50 % of span) to 90 % of full scale.

Set the low (red) setpoint knob to zero pressure and the high (black) setpoint to full scale pressure. With a suitable pressure source on a workbench, apply pressure to the gauge and allow sufficient time for the pressure reading to stabilize. If a workbench pressure source is not available or if time doesn't permit bench testing, use the pressure generated in your process by which to test the proper functioning of these contacts.

To test the low setpoint contact, rotate the low (red) setpoint knob clockwise until the contact arm makes contact with the pointer. A low switch contact will be made. Return the low setpoint contact arm to a position zero pressure or to some other desired pressure point below the pointer.

KT-083

11/04

Page 4 of 12

To test the high setpoint contact, rotate the high (black) setpoint knob counter-clockwise until the contact arm makes contact with the pointer. A high switch contact will be made. Return the high setpoint contact arm to either the full scale position or to some other desired pressure point above the pointer.

Once you've verified proper functioning of the gauge setpoint contact(s), install the gauge into service and apply pressure. Once the pressure reading stabilizes, adjust the setpoint(s) on the Switch Gauge to its proper position(s) based on your application.

MAINTENANCE

The 3D Instruments Accu-Switch setpoint gauge is designed to be part of a system to protect critical machinery and processes. As part of a preventative maintenance plan, these gauges should periodically be inspected and tested for proper operation. Visually check that the indicated pressure is in keeping with expected readings and that the needle is not frozen, distorted or otherwise inaccurate. Pressure fittings and tubing should be inspected to insure against leaks and blockages that could impair proper operation of the gauge. Periodically adjust the high and low knobs to cause action of the limit switches and proper alarm or shutdown action per the design of the overall safety shutdown system.

If the gauge seems to be working improperly, consider the possibilities that may be causing the difficulty. If the zero is off only slightly it may have been caused by overpressures that were slightly more than 150% of the full scale range of the gauge. In this case, the zero may be reset by using a small screwdriver to turn the drive at the bottom of the dial face on the outside of the case which, in turn, rotates the gauge dial.

If over pressure has been applied in excess of 150% of the full scale range, it will be necessary to check the calibration of the gauge after resetting the zero. The gauge accuracy is guaranteed only when over pressures are less than 150% of the full scale range of the gauge. When checking the gauge calibration, it is necessary to use a reference pressure device with an accuracy of 0.25% or better. The calibration should be checked at 20% increments. These points should be checked while increasing the pressure from zero to the full scale reading and then again while decreasing the pressure from the full-scale reading to zero. Be sure that true zero pressure occurs in the pressure system at zero reading.

A leak may be indicated by continuously decreasing gauge readings, particularly if the pressure has been "trapped" by a valve. If this is the case, check all components in the pressure system, including the fittings and the valve, for leakage.

The gauge may be blocked and require cleaning. Contamination from the pressure media may be present. It may be necessary to remove and clean or replace the particulate filter. Certain accessory devices, such as isolators and pressure snubbers should be considered in certain applications.

It should not be necessary to open a 3D Instruments Accu-Switch series gauge for adjustment, repair or other purposes. If the gauge seems to be working improperly, please follow the instructions above. If the gauge is still not working properly, return the gauge for factory service. Refer to back page for factory contact information.

ACCU-SWITCH ORDERING INFORMATION

① ② ③ ④ ⑤ ⑥ ⑦
 29 X 04 - XX X XX XXX GAD ISOD

Example:

29504 - 33C21 GAD ISOD 0-3000 psi/0-20 MPa dual scale, 4 1/2" Black ABS case, front flange, 1/2" NPTM back connection, vibration dampener

- ① **Product Description:**
29: Accu-Switch line of Switch Gauges
- ② **Pressure Ranges:**
1: Compound scale (Vacuum/Positive pressure - only available on 0-30 and 0-100 psi ranges)
5: Positive pressure scale (not used for compound scales)
- ③ **Dial Size:**
04: 4 1/2" (approximately 114 mm)
- ④ **Pressure Range Codes: (Note: psi/kPa or psi/MPa dual scales are standard)**
48: 30" Hg(vac) -0-30 psi/-100-0-200 kPa **23:** 30" Hg(vac) -0-100 psi/-100-0-700 kPa
21: 0-30 psi/200 kPa **25:** 0-200 psi/1400 kPa **29:** 0-1000 psi/7000 kPa
22: 0-60 psi/400 kPa **26:** 0-300 psi/2000 kPa **32:** 0-2000 psi/14 MPa
23: 0-100 psi/700 kPa **27:** 0-500 psi/3500 kPa **33:** 0-3000 psi/20 MPa
45: 0-160 psi/1100 kPa **28:** 0-600 psi/4000 kPa **35:** 0-5000 psi/35 MPa
- ⑤ **Process Connection:**
B: 1/4" NPT (male)
C: 1/2" NPT (male)
- ⑥ **Fitting/Flange Combination/Case type: (Black ABS case type standard)**
11: flange front, fitting bottom
21: flange front, fitting back
31: flange back, fitting bottom
41: flange back, fitting back
51: flange none, fitting bottom
61: flange none, fitting back
- ⑦ **Option Codes:**
GAD: High viscosity silicone oil vibration dampener (**standard**)
ISOD: Dual scale psi/kPa or psi/MPa (**standard**) – remove ISOD from the part number for PSI only single scales. For custom scales, contact factory.
EFF: Special flange with metric bolt pattern - contact factory for details.

SPECIFICATIONS

Measurement:

Accuracy: +/- 1 % of Full Scale
Repeatability: +/- 0.025% Full Scale
Sensitivity: +/- 0.025% Full Scale

Accuracy specification includes all variations due to: non-linearity, hysteresis, repeatability and temperature over the operating range.

Pressure Ranges:

Dials are configured **standard** with dual scales: PSI (outer rings) and either kPa or MPa (inner ring)

| Vacuum/PSI | kPa/MPa |
|--------------------|----------------|
| 30" Hg/vac-30 psi | -100-0-200 kPa |
| 30" Hg/vac-100 psi | -100-0-700 kPa |
| 0-30 psi | 0-200 kPa |
| 0-60 psi | 0-400 kPa |
| 0-100 psi | 0-700 kPa |
| 0-160 psi | 0-1100 kPa |
| 0-200 psi | 0-1400 kPa |
| 0-300 psi | 0-2000 kPa |
| 0-500 psi | 0-3500 kPa |
| 0-600 psi | 0-4000 kPa |
| 0-1,000 psi | 0-7000 kPa |
| 0-2,000 psi | 0-14 MPa |
| 0-3,000 psi | 0-20 MPa |
| 0-5,000 psi | 0-35 MPa |

Environmental:

Ambient Temp: -65 °F-190 °F (-54 °C-88 °C)
 Service Media Temp: -65 °F-400 °F (-54 °C-204 °C)

Setpoint Switch Rating

125 Volt @ 0.25 amps (AC or DC)

Dial Sizes

4 1/2" (approximately 114 mm)

Process Connection:

Available in 1/4" NPT or 1/2" NPT (male)

Mounting Flange (optional):

Front or back versions - ABS Plastic
 ANSI bolt pattern for 4 1/2" gauge

Materials of Construction:

- Case: ABS Plastic, black
- Lens: Polycarbonate
- Sensing element: Inconel X-750
- Capillary Tube: 316 Stainless Steel
- Process Connection: 316 Stainless Steel
- Contacts: Gold Plated Nickel Silver

Figure 1

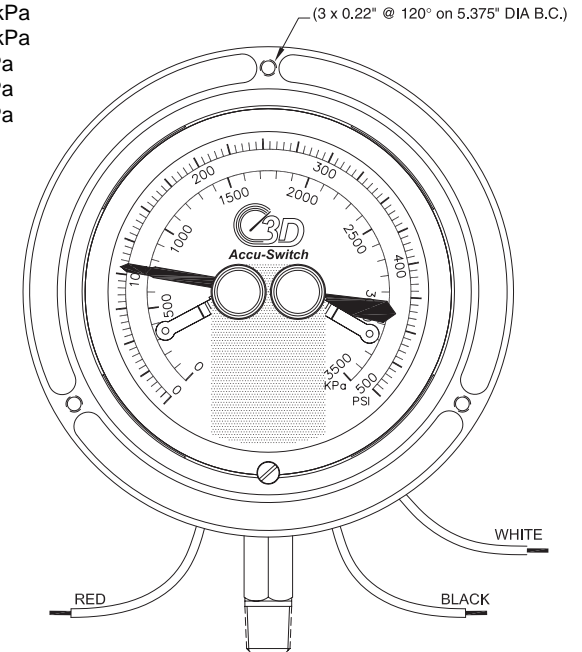
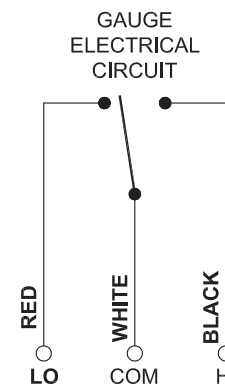

(NOTE: PICTURED WITH OPTIONAL FLANGE)

Figure 2

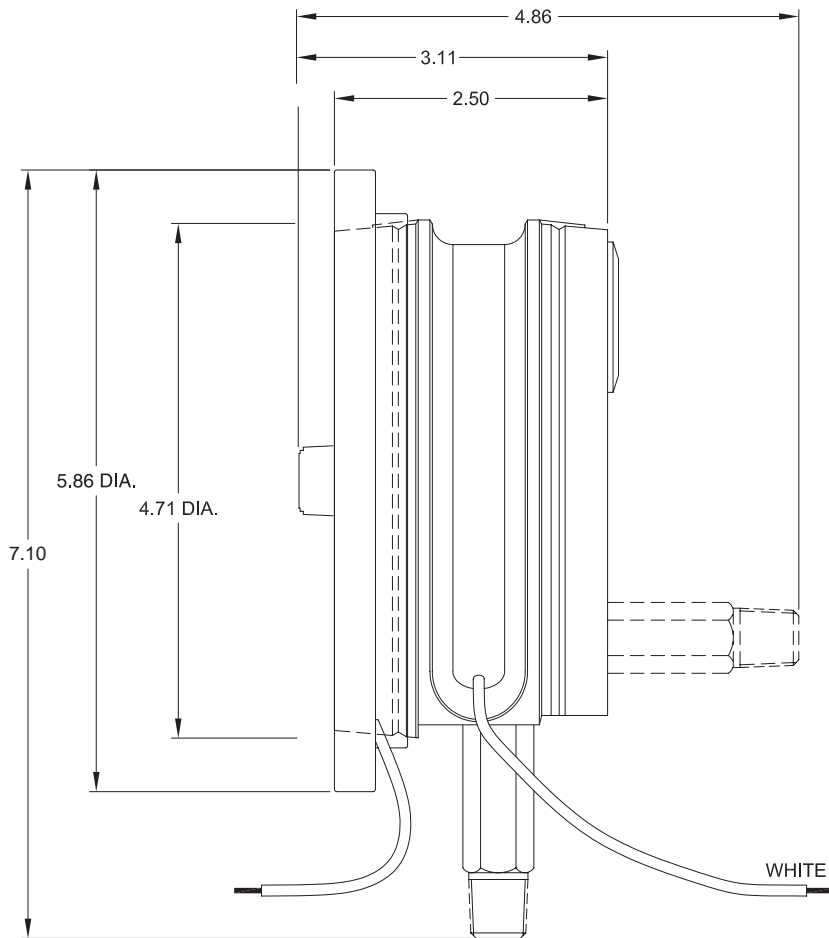

(NOTE: PICTURED WITH OPTIONAL FLANGE)

Figure 3

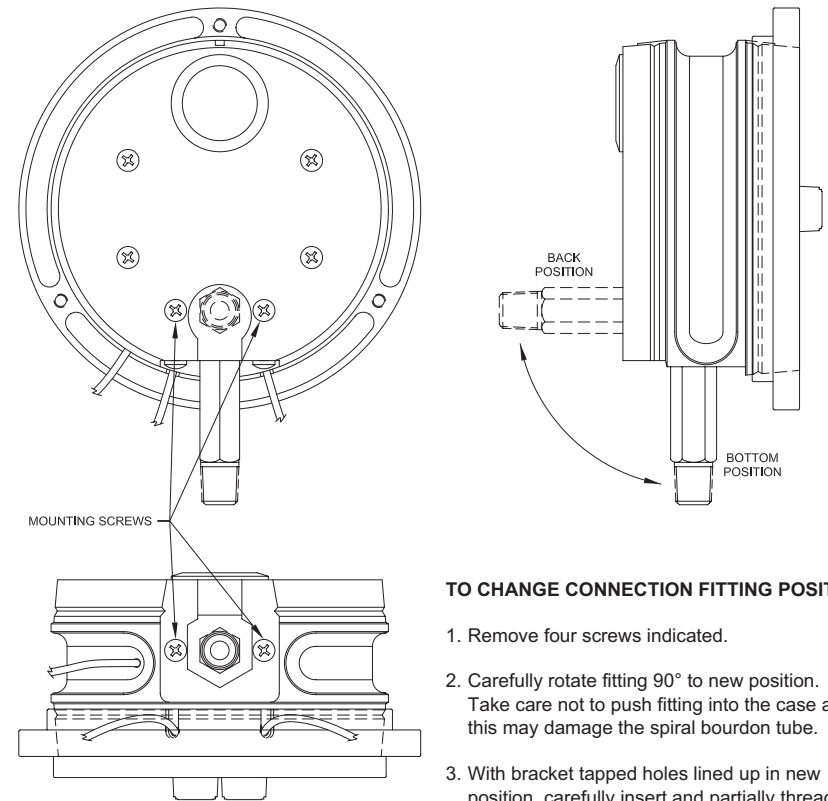

TO CHANGE CONNECTION FITTING POSITION:

1. Remove four screws indicated.
2. Carefully rotate fitting 90° to new position.
Take care not to push fitting into the case as this may damage the spiral bourdon tube.
3. With bracket tapped holes lined up in new position, carefully insert and partially thread into place all four attaching screws. When bracket is correctly positioned, tighten four screws.

NOTE: DO NOT attempt to change the fitting orientation for pressure ranges below 60 psi.

(NOTE: PICTURED WITH OPTIONAL FLANGE)

WARRANTY

3D Instruments, LLC warrants the Accu-Switch to be free from defects in material and workmanship under normal use and service for six (6) years from date of purchase to the original purchaser. It does not apply when the product has been misused, altered or damaged by accident or abnormal conditions of operation.

Within six (6) years from date of purchase, 3D Instruments will, at our option, repair or replace a defective device free of charge and the device will be returned, transportation prepaid. However, if we determine the failure was caused by misuse, alteration, accident or abnormal condition of operation, you will be billed for the repair.

3D INSTRUMENTS, LLC MAKES NO WARRANTY OTHER THAN THE LIMITED WARRANTY STATED ABOVE. ALL WARRANTIES, INCLUDING IMPLIED WARRANTIES OF MERCHANTABILITY OR FITNESS FOR ANY PARTICULAR PURPOSE, ARE LIMITED TO A PERIOD OF SIX (6) YEARS FROM THE DATE OF PURCHASE. 3D INSTRUMENTS, LLC SHALL NOT BE LIABLE FOR ANY SPECIAL, INCIDENTAL OR CONSEQUENTIAL DAMAGES, WHETHER IN CONTRACT, TORT OR OTHERWISE.

For warranty or non-warranty service, we can be reached at:

Phone.....714•399•9200

Fax.....714•399•9220

Email.....info@3dinstruments.com

Address.....3D Instruments, LLC
Attn: Accu-Switch Service Department
2900 E. White Star Avenue
Anaheim, CA 92806
U.S.A.

Webwww.3dinstruments.com

Return Authorization is not required for servicing. Please return, Freight Prepaid, to the address above and include a Contact Name, Address, Phone and Fax Number. If you wish to be notified of the charges before any service is done, 3D Instruments will contact you after evaluating the unit. Units evaluated but not serviced are subject to an evaluation charge. Defective units need to be returned to 3D Instruments, LLC within 90 days of identification of a problem.

©2004 3D Instruments, LLC

2900 E. White Star Avenue

Anaheim, CA 92806

Ph: 714•399•9200

Fax: 714•399•9220

E-mail: info@3dinstruments.com

Web Sites

<http://www.3dinstruments.com>

<http://www.3dhub.com>

<http://www.digitalpressuregauge.com>

The "Direct Drive Difference" in Switch Gauges



INSTRUMENTS, LLC
Direct Drive Difference
SIERRA PRECISION